

BRACKET ORDER # CMS-445

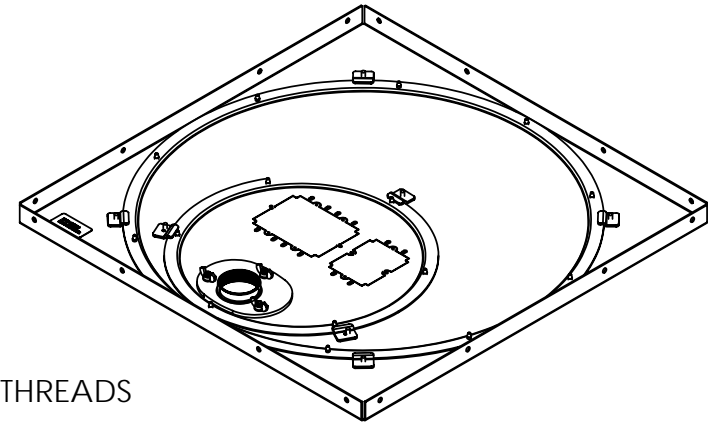

1.5" NPSM THREADS

R 8.50
ADJUSTABLE IN THIS RADIUS

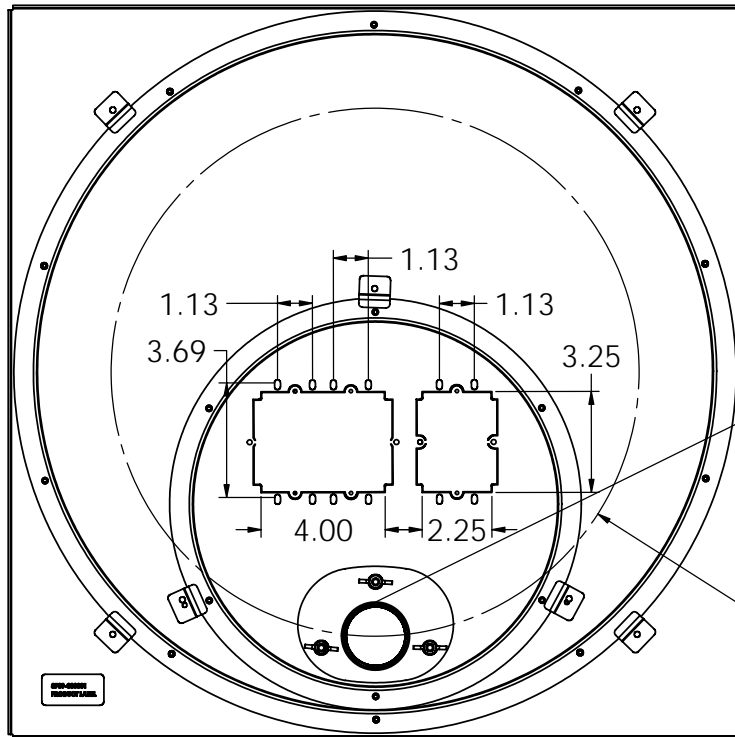
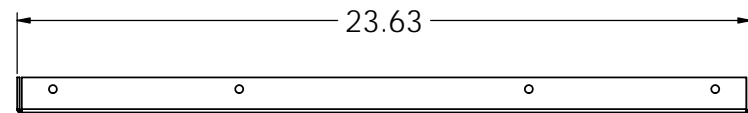
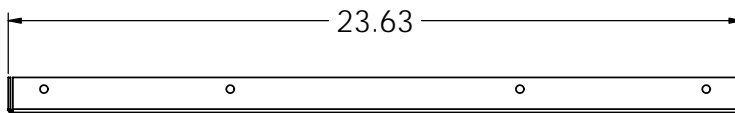

4X 1.13



CHIEF MANUFACTURING INC.

PRODUCT ORDER NUMBER IS CMS-445
PHONE: 1-800-582-6480

THE INFORMATION AND DESIGNS CONTAINED IN THIS DRAWING ARE CONFIDENTIAL AND THE PROPRIETARY PROPERTY OF CHIEF MFG., INC. NEITHER THIS DESIGN NOR ANY INFORMATION CONTAINED IN THIS DRAWING MAY BE REPRODUCED OR DISCLOSED TO OTHERS WITHOUT THE EXPRESS WRITTEN CONSENT OF CHIEF MFG., INC.

CHIEF 8401 EAGLE CREEK PKY
SAVAGE, MN 55378
PHONE: 952-894-6280
FAX: 877-894-6918

TITLE
CUSTOMER PRINT
CMS-445 SPEED CONNECT
SUSPENDED CEILING PLATE,

SIZE: DWG. NO.
B BRACKET ORDER # CMS-445

1 2 3 4 5 6 7 8